

KARTA TECHNICZNA

KOLANO TĘPE 40°

W-WKT

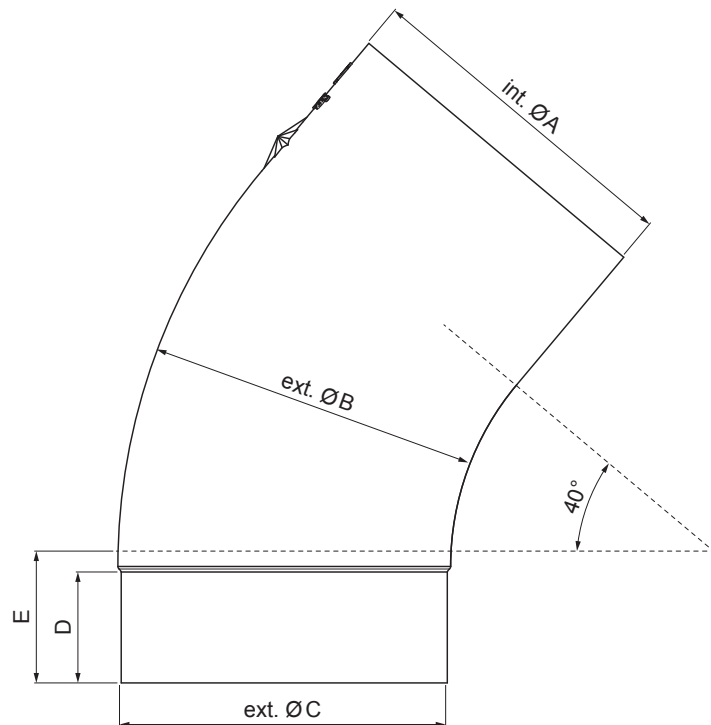

W Aluminium – Natur

Wymiary [mm]					
Rozmiar nominalny	Ø A	Ø B	Ø C	D	E
80	80,4	79	76,9	28	40
100	100,4	99,0	96,8	35	50
120	120,3	119,0	116,7	42	60

INDEKS	ZMIANA	DATA	PODPIS	KJG QUALITY®	Scan code for 3D model	
ZN. MAT.			K.O.	MASA kg	SKALA	
WYM. PÓLT.					Norma STN	NR KL.
POM. URZ.					ZMIAN.	NR POL.
SPORZ. Ing. Kluska M.					STARY RYS.	NR RYS.
SPRAW.						
TECHNOL.			TECHNOL.			
NAZWA			Kolano tępe 40°		Liczba arkuszy	W-WKT Arkusz

Utworzone: 21.04.2026 10:13:11

Zmiany techniczne zastrzeżone