

KARTA TECHNICZNA

DYSTRYBUTOR WODY

P-PRV

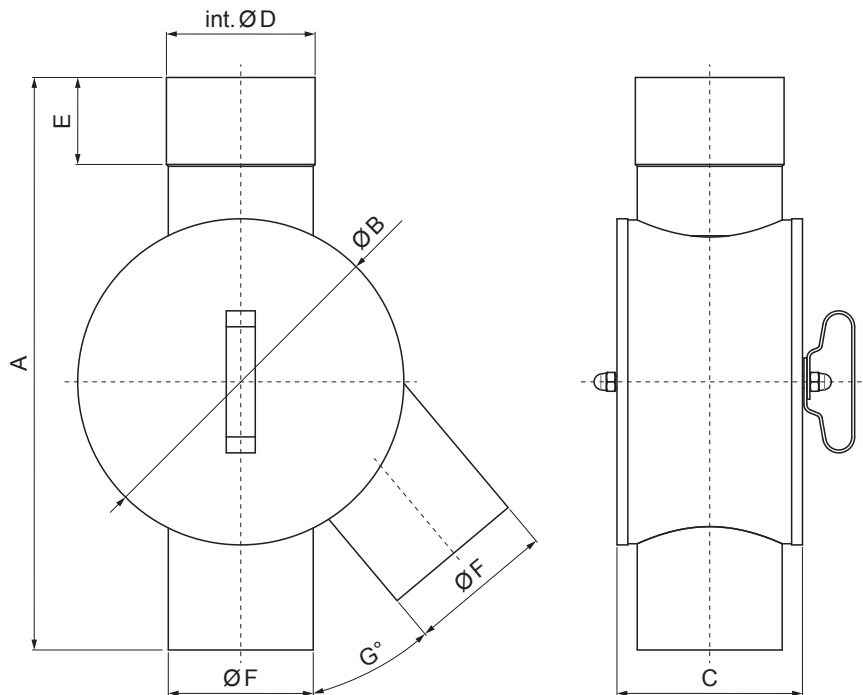

TZ Ocynkowana stal powlekana – Trawa zielona – RAL 6011

Wymiary [mm]								
Rozmiar nominalny	A	ØB	C	int. ØD	E	ØF	G	Przepływ
80	335	180	108	81	55	80	40	5,9 l/s
100	395	225	128	101	60	100	40	10,7 l/s
120	385	225	140	121	60	120	60	17,4 l/s

INDEKS	ZMIANA	DATA	PODPIS	KJG QUALITY®	Scan code for 3D model	
ZN. MAT						
WYM. PÓLT.						
POM. URZ.				Norma STN	NR KL.	
SPORZ.	Ing. Kluska M.			ZMIAN.	NR POL.	
SPRAW.						
TECHNOL.	TECHNOL.			STARY RYS.	NR RYS.	
NAZWA	Dystrybutor wody			Liczba arkuszy	P-PRV	Arkusze

Utworzone: 21.04.2026 23:37:12

Zmiany techniczne zastrzeżone