

KARTA TECHNICZNA

# DYSTRYBUTOR WODY

# P-PRV

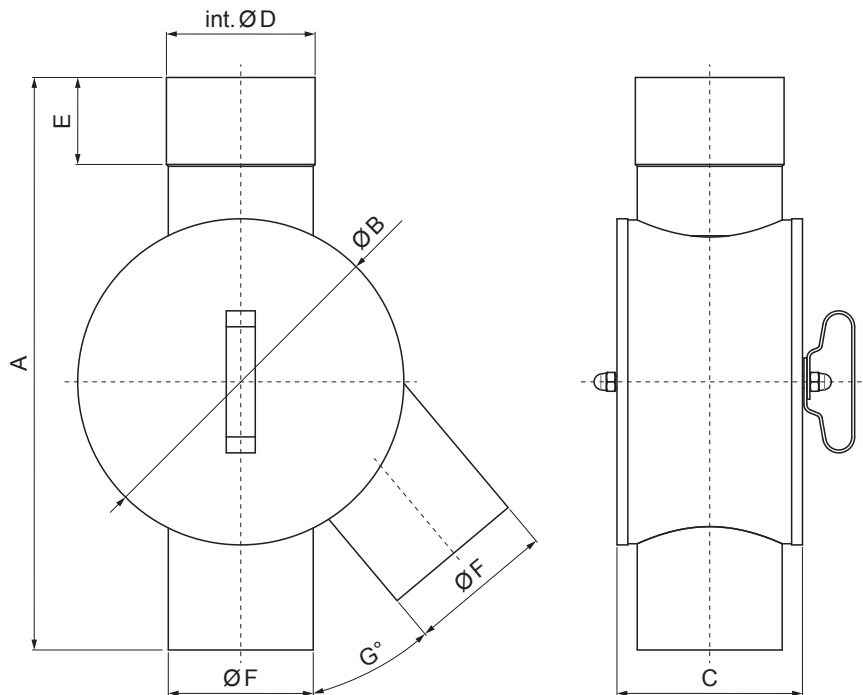

**SB** Ocynkowana stal powlekana – Szaro biały – RAL 9002

Wymiary [mm]								
Rozmiar nominalny	A	ØB	C	int. ØD	E	ØF	G	Przepływ
80	335	180	108	81	55	80	40	5,9 l/s
100	395	225	128	101	60	100	40	10,7 l/s
120	385	225	140	121	60	120	60	17,4 l/s

INDEKS	ZMIANA	DATA	PODPIS	<b>KJG</b> QUALITY®	Scan code for 3D model	
ZN. MAT			K.O.	MASA kg	SKALA	
WYM. PÓLT.				Norma STN		NR KL.
SPORZ.		Ing. Kluska M.	ZMIAN.		NR POL.	
SPRAW.			STARY RYS.		NR RYS.	
TECHNOL.		TECHNOL.	STARY RYS.		NR RYS.	
NAZWA				Dystrybutor wody		Liczba arkuszy
				P-PRV		Arkuszy

Utworzone: 21.04.2026 23:54:59

Zmiany techniczne zastrzeżone