

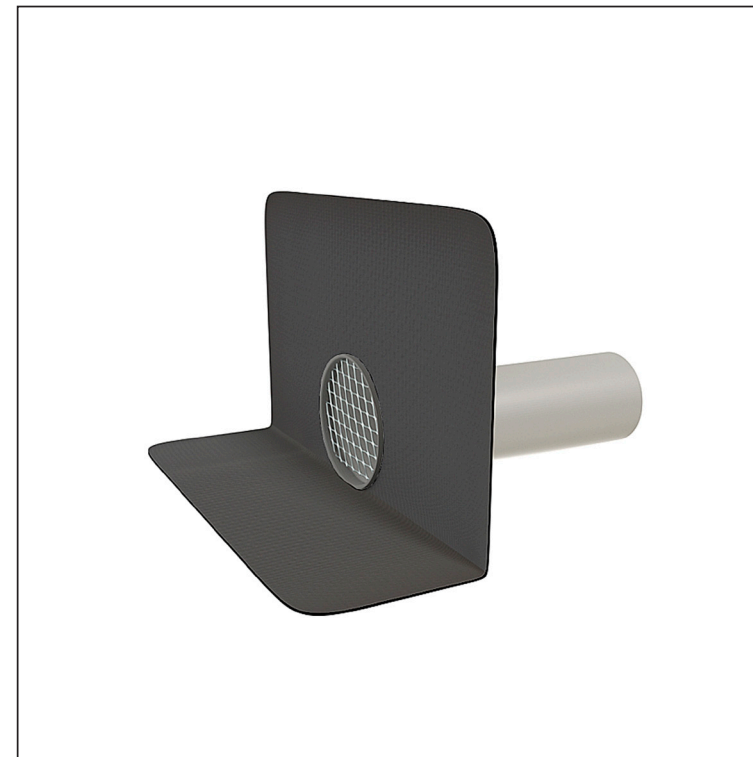

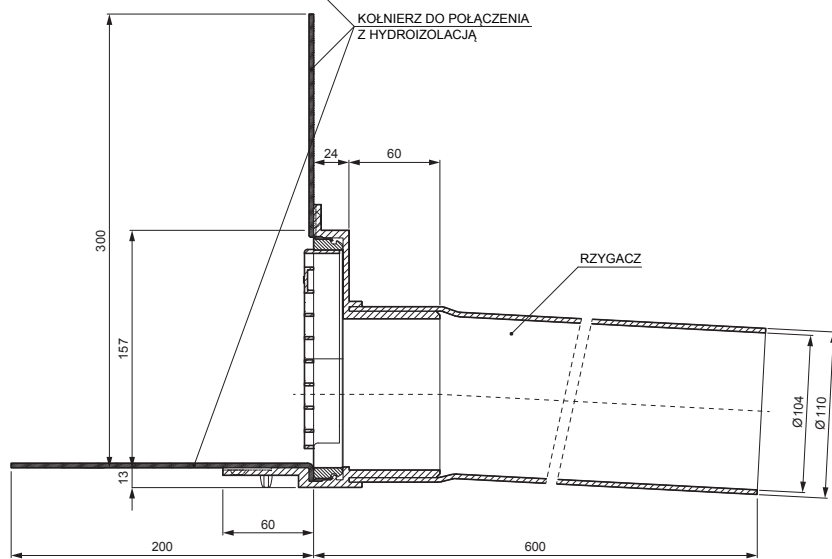
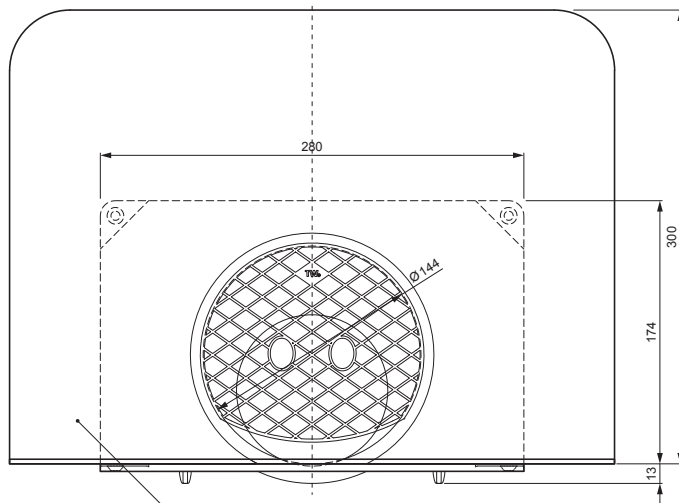

KARTA TECHNICZNA

# FPO GARGULEC OKRĄGŁY Z KOŁNIERZEM

# TWS-TWC F



**B** PVC – Biały – RAL 9010

INDEKS	ZMIANA	DATA	PODPIS	 	
ZN. MAT			K.O.		MASA kg
WYM. PÓŁT.					SKALA
POM. URZ.				Norma STN	NR KL.
SPORZ.	Ing. Kluska M.			ZMIAN.	NR POL.
SPRAW.					
TECHNOL.		TECHNOL.		STARY RYS.	NR RYS.
NAZWA	FPO gargulec okrągły z kołnierzem			Liczba arkuszy	TWS-TWC F
					Arkusz 

Utworzone: 23.04.2026 18:34:03

Zmiany techniczne zastrzeżone